



US 20190252616A1

(19) **United States**

(12) **Patent Application Publication**  
**KONG et al.**

(10) **Pub. No.: US 2019/0252616 A1**

(43) **Pub. Date: Aug. 15, 2019**

(54) **DISPLAY PANEL AND MANUFACTURING METHOD THEREOF, AND DISPLAY DEVICE**

(52) **U.S. Cl.**  
CPC ..... *H01L 51/0024* (2013.01); *H01L 51/5228* (2013.01); *H01L 51/0023* (2013.01); *H01L 51/525* (2013.01); *H01L 27/322* (2013.01); *H01L 51/5218* (2013.01); *H01L 51/56* (2013.01); *H01L 51/5271* (2013.01); *H01L 51/5036* (2013.01); *H01L 51/5234* (2013.01)

(71) Applicant: **BOE TECHNOLOGY GROUP CO., LTD.**, Beijing (CN)

(72) Inventors: **Xiangyong KONG**, Beijing (CN);  
**Dongfang WANG**, Beijing (CN)

(21) Appl. No.: **16/393,153**

(57) **ABSTRACT**

(22) Filed: **Apr. 24, 2019**

**Related U.S. Application Data**

(63) Continuation of application No. 14/422,271, filed on Feb. 18, 2015, filed as application No. PCT/CN2014/082240 on Jul. 15, 2014.

**Foreign Application Priority Data**

(30) Nov. 11, 2013 (CN) ..... 201310557149.5

**Publication Classification**

(51) **Int. Cl.**  
*H01L 51/00* (2006.01)  
*H01L 51/52* (2006.01)  
*H01L 51/56* (2006.01)  
*H01L 51/50* (2006.01)

The disclosure provides a display panel and a manufacturing method thereof. The display panel display panel comprises a first substrate and a second substrate which are assembled, the second substrate is provided with an organic electroluminescent device thereon, an anode layer of the organic electroluminescent device is away from the first substrate and a cathode layer thereof is closer to the first substrate than the anode layer; the cathode layer of the organic electroluminescent device is electrically connected to an auxiliary electrode on a light entering surface of the first substrate through multiple conductive spacers, the cathode layer is a transparent electrode layer; the auxiliary electrode has a resistance smaller than that of the cathode layer of the organic electroluminescent device; the auxiliary electrode is a grid-shaped auxiliary electrode and is provided in a non-display region, the auxiliary electrode is opaque and acts as a black matrix.

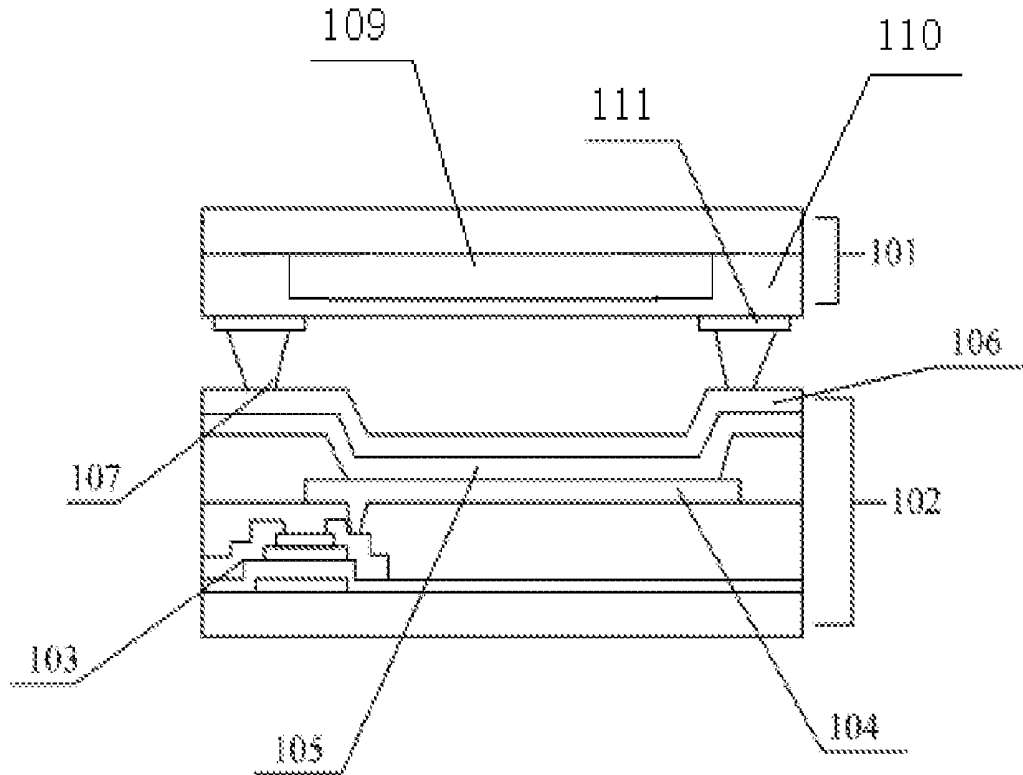

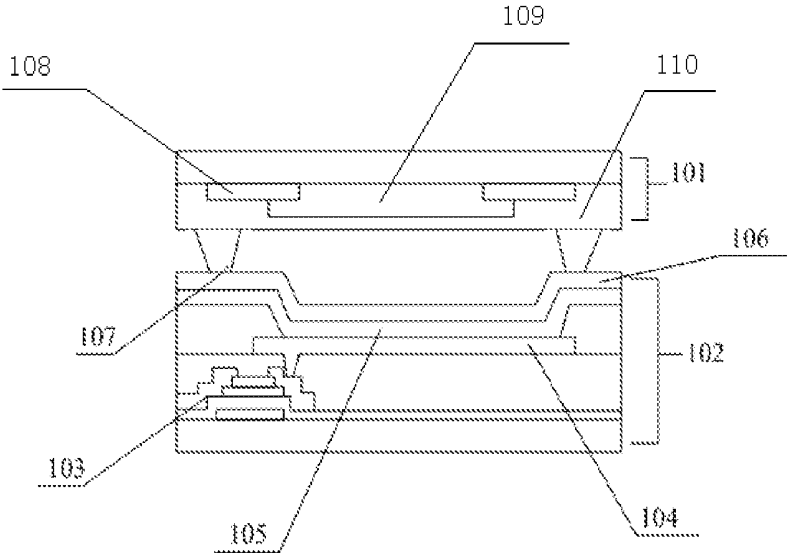

Fig. 1

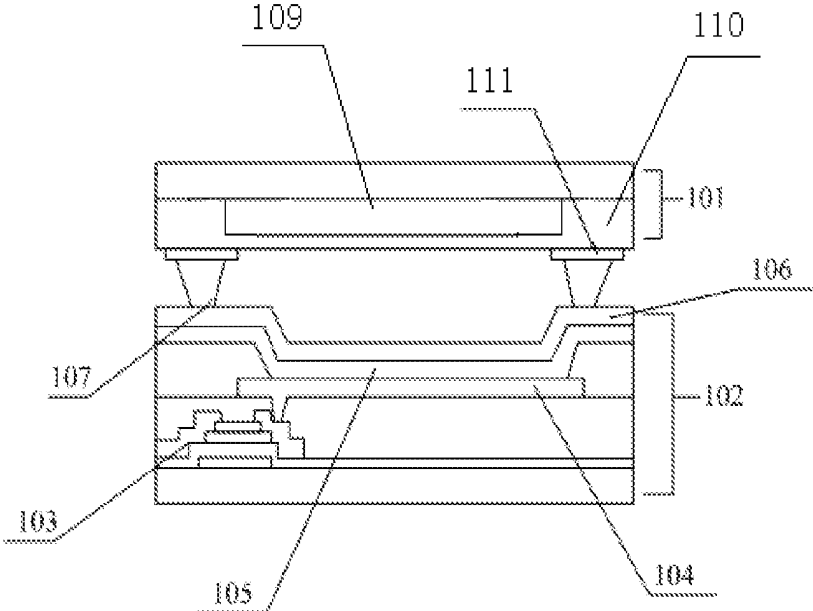

Fig. 2

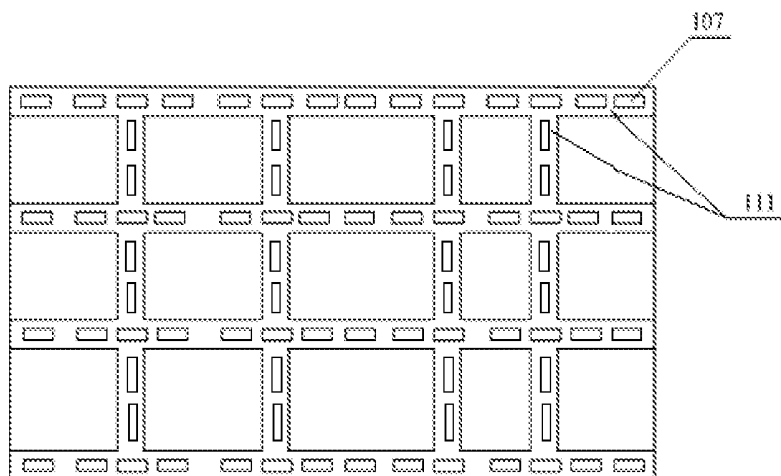

Fig. 3

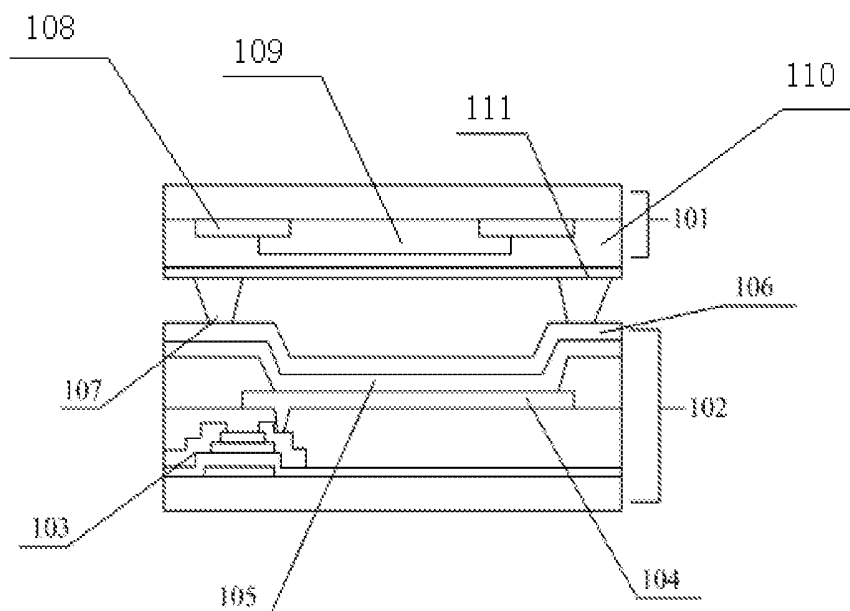

Fig. 4

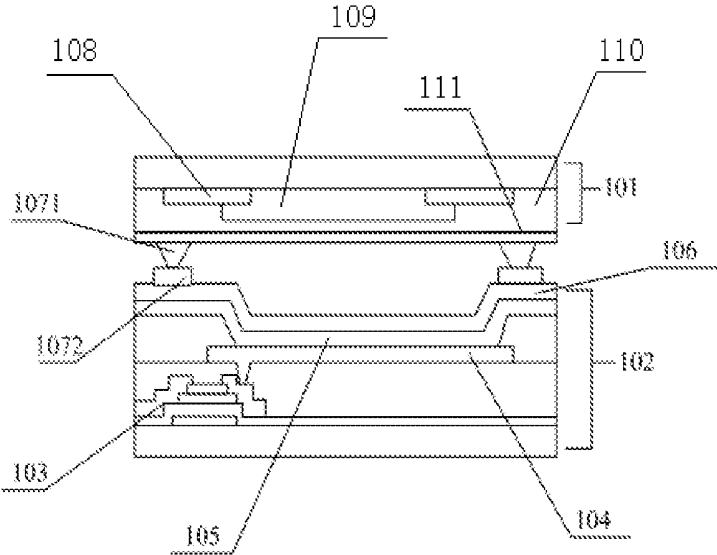

Fig. 5

## DISPLAY PANEL AND MANUFACTURING METHOD THEREOF, AND DISPLAY DEVICE

### FIELD OF THE INVENTION

[0001] The present disclosure relates to the field of the display device manufacturing technology, and particular to a display panel and a manufacturing method thereof, and a display device.

### BACKGROUND OF THE INVENTION

[0002] In recent years, the display technology has been developed rapidly, and especially the organic electroluminescent device (OLED) display technology has been developed rapidly. Currently, there are mainly two kinds of technologies for coloring large-sized white organic electroluminescent devices (WOLEDs), one of which is to form a display panel by directly manufacturing color filter patterns on a second substrate (COA, color filter on array), and the other of which is to form a display panel by assembling a first substrate and a second substrate, and providing spacers arranged spaced at certain intervals between the first substrate and the second substrate, wherein the spacers are used to support the first substrate and the second substrate.

### SUMMARY OF THE INVENTION

[0003] An embodiment of the present disclosure provides a manufacturing method of a display panel, including steps of: forming a pattern including an auxiliary electrode on a light entering surface of a first substrate by a patterning process; forming a pattern including conductive spacers on at least one of the auxiliary electrode and a cathode layer of a second substrate by a patterning process; and assembling the first substrate and a second substrate, so that the auxiliary electrode is electrically connected to a cathode layer of an organic electroluminescent device through the conductive spacers, wherein the cathode layer is a transparent electrode layer.

[0004] In some implementations, forming a pattern including conductive spacers on at least one of the auxiliary electrode and a cathode layer of a second substrate by a patterning process includes:

[0005] forming a pattern including conductive spacers on the auxiliary electrode by a patterning process.

[0006] In some implementations, forming a pattern including conductive spacers on at least one of the auxiliary electrode and a cathode layer of a second substrate by a patterning process includes:

[0007] forming a pattern including conductive spacers on the cathode layer of the second substrate at positions corresponding to the auxiliary electrode by a patterning process.

[0008] In some implementations, forming a pattern including conductive spacers on at least one of the auxiliary electrode and a cathode layer of a second substrate by a patterning process includes:

[0009] forming a pattern including first conductive spacers on the auxiliary electrode by a patterning process, and forming a pattern including second conductive spacers on the cathode layer of the second substrate at positions corresponding to the first conductive spacers by a patterning process.

[0010] In some implementations, assembling the first substrate and a second substrate, so that the auxiliary electrode

is electrically connected to a cathode layer of an organic electroluminescent device through the conductive spacers includes:

[0011] assembling the first substrate and the second substrate, so that the auxiliary electrode is electrically connected to the cathode layer of the organic electroluminescent device through the first conductive spacers and the second conductive spacers.

[0012] In some implementations, the auxiliary electrode has a resistance smaller than that of the cathode layer of the organic electroluminescent device.

[0013] In some implementations, the conductive spacers are made of any one of polyacetylene, PPV, polythiophene, poly p-phenylene, polypyrrole, polyaniline, poly(3,4-ethylenedioxythiophene) or combination thereof.

[0014] In some implementations, a surface area of an end of the first conductive spacer facing the second conductive spacer is smaller than that of an end of the second conductive spacer facing the first conductive spacer.

[0015] In some implementations, the auxiliary electrode is formed as a plate-shaped auxiliary electrode which is transparent and conductive.

[0016] In some implementations, the plate-shaped auxiliary electrode is made of any one of indium tin oxide, indium gallium zinc oxide, and indium zinc oxide.

[0017] In some implementations, the auxiliary electrode is formed as a grid-shaped auxiliary electrode and provided in a non-display region.

[0018] In some implementations, the grid-shaped auxiliary electrode is made of any one of Al, Mo, Cu, Ag, Cr and Au or a combination thereof.

[0019] In some implementations, the manufacturing method further including: forming a reflective layer below an anode layer of the organic electroluminescent device, and the reflective layer is configured to reflect light emitted from the organic electroluminescent device to the cathode layer of the organic electroluminescent device.

[0020] An embodiment of the present disclosure provides a display panel including a first substrate and a second substrate which are assembled, wherein the second substrate is provided with an organic electroluminescent device thereon, an anode layer of the organic electroluminescent device is away from the first substrate and a cathode layer thereof is closer to the first substrate than the anode layer; the cathode layer of the organic electroluminescent device is electrically connected to an auxiliary electrode on a light entering surface of the first substrate through a plurality of conductive spacers spaced, and the cathode layer is a transparent electrode layer; and the auxiliary electrode has a resistance smaller than that of the cathode layer of the organic electroluminescent device; wherein the auxiliary electrode is a grid-shaped auxiliary electrode and is provided in a non-display region, and the auxiliary electrode is opaque and acts as a black matrix.

[0021] In some implementations, the grid-shaped auxiliary electrode is made of any one of Al, Mo, Cu, Ag, Cr and Au or a combination thereof.

[0022] An embodiment of the present disclosure provides display device including the above display panel.

[0023] An embodiment of the present disclosure provides display panel including a first substrate and a second substrate which are assembled, wherein the second substrate is provided with an organic electroluminescent device thereon, an anode layer of the organic electroluminescent device is

away from the first substrate and a cathode layer thereof is closer to the first substrate than the anode layer; the cathode layer of the organic electroluminescent device is electrically connected to an auxiliary electrode on a light entering surface of the first substrate through a plurality of conductive spacers spaced, and the cathode layer is a transparent electrode layer; and the auxiliary electrode has a resistance smaller than that of the cathode layer of the organic electroluminescent device; wherein the auxiliary electrode includes a plurality of bar-shaped auxiliary electrodes connected to each other through at least one connection stripe.

[0024] In some implementations, the bar-shaped auxiliary electrode is made of any one of Al, Mo, Cu, Ag, Cr and Au or a combination thereof.

[0025] An embodiment of the present disclosure provides a display device including the above display panel.

#### BRIEF DESCRIPTION OF THE DRAWINGS

[0026] FIG. 1 is a structural diagram of a display panel in the prior art;

[0027] FIG. 2 is a structural diagram of a display panel according to embodiment 1 of the disclosure;

[0028] FIG. 3 a top view of an auxiliary electrode, which is a grid-shaped auxiliary electrode, of the display panel according to embodiment 1 of the disclosure;

[0029] FIG. 4 is another structural diagram of a display panel according to embodiment 1 of the disclosure; and

[0030] FIG. 5 is a structural diagram of a display panel manufactured by a manufacturing method of a display panel according to embodiment 4 of the disclosure.

[0031] Reference signs: **101** first substrate; **102** second substrate; **103** thin film transistor; **104** pixel electrode layer (anode layer); **105** light emitting layer; **106** cathode layer; **107** (conductive) spacer; **1071** first conductive spacer; **1072** second conductive spacer; **108** black matrix; **109** color filter pattern; **110** planarization layer; **111** (plate/grid-shaped) auxiliary electrode.

#### DETAILED DESCRIPTION OF EMBODIMENTS

[0032] In order to make persons skilled in the art better understand the solutions of the disclosure, the disclosure will be described below in detail in conjunction with drawings and embodiments.

[0033] As shown in FIG. 1, for a display panel consisting of a second substrate **102** and a first substrate **101**, the first substrate **101** includes black matrixes **108**, color filter patterns **109** of various colors provided above the black matrixes **108**, and a planarization layer **110** provided above the black matrixes **108** and the color filter patterns **109** of various colors; a drain of a thin film transistor **103** on the second substrate **102** is electrically connected to an anode layer **104** of an organic electroluminescent device, the anode layer **104** is provided at one side close to the second substrate **102**, a cathode layer **106** of the organic electroluminescent device is provided at one side far away from the second substrate **102**, a light emitting layer **105** is provided between the anode layer **104** and the cathode layer **106**, and a plurality of organic electroluminescent devices are provided on the second substrate **102**, the anode layers **104** of the organic electroluminescent devices are controlled by different thin film transistors **103** respectively, all of the cathode layers **106** are connected together, spacers **107** supports the first substrate **101** and the second substrate **102** therebe-

tween, at this time, light emitted from the organic electroluminescent devices transmits the cathode layer **106**, that is to say, the organic electroluminescent device is of a top-emitting type, the cathode layer **106** is commonly made of conductive material such as silver (Ag) and aluminium (Al), light transmission of which is low, thus it is required to select very thin conductive material so that light may transmit. It should be noted that, after the first substrate **101** and the second substrate **102** are manufactured separately, the first substrate **101** and the second substrate **102** are assembled to form a display panel, wherein the spacers **106** may be formed on the first substrate **101** or on the second substrate **102**.

[0034] The inventor finds that, in the organic electroluminescent device of top-emitting type adopted in the above display panel, the cathode layer **106** is thin due to requirement on transmittance, resulting in the fact that the cathode layer **106** has large resistance, and poor conductivity, therefore the light emitting performance of the organic electroluminescent device is poor, and the display effect is nonuniform.

#### Embodiment 1

[0035] As shown in FIGS. 2, 3, 4 and 5, the present embodiment provides a display panel, which comprises a first substrate **101** and a second substrate **102** which are assembled, the second substrate **102** is provided with organic electroluminescent devices thereon, an anode layer **104** of the organic electroluminescent device is far away from the first substrate **101** and a cathode layer **106** thereof is close to the first substrate **101**; and the cathode layer **106** of the organic electroluminescent device is electrically connected to an auxiliary electrode **111** on a light entering surface of the first substrate **101** through a plurality of conductive spacers **107** spaced at certain intervals, wherein the cathode layer **106** is a transparent electrode layer.

[0036] The second substrate **102** of the display panel of the embodiment includes a plurality of organic electroluminescent devices, an anode layer **104** of each of the organic electroluminescent devices is separately controlled by a separated thin film transistor **103**, cathode layers **106** of all of the organic electroluminescent devices are connected together, and the light entering surface of the first substrate **101** is provided with the auxiliary electrode **111**, which is electrically connected to the cathode layers **106** of the organic electroluminescent devices through the conductive spacers **107** so as to improve the conductivity of the cathode layers **106**, and thus improve the luminance uniformity of the display panel.

[0037] Preferably, the auxiliary electrode **111** has a resistance smaller than that of the cathode layer **106** of the organic electroluminescent device, thus an IR drop of the cathode layer **106** may be prevented or decreased, the conductivity of the cathode layer **106** is enhanced due to the auxiliary electrode, and thus the luminance uniformity of the display panel may be improved.

[0038] The conductive spacer **107** is preferably made of any one of polyacetylene, PPV, polythiophene, poly p-phenylene, polypyrrole, polyaniline, poly(3,4-ethylenedioxythiophene) or combination thereof. Of course, the disclosure is not limited thereto. The conductive spacer **107** may be made of any other material, so long as it is conductive and plays a supporting role.

[0039] The conductive spacer **107** may be of an integrated structure, and may be provided on the first substrate **101** or

the second substrate **102** for supporting the first substrate **101** and the second substrate **102** when assembled. The conductive spacer **107** may preferably include, as shown in FIG. 5, a first conductive spacer **1071** and a second conductive spacer **1072** which are connected to each other, for example, the first conductive spacer **1071** is provided on the first substrate **101**, and the second conductive spacer **1072** is provided on the second substrate **102**, and a surface area of an end of the first conductive spacer **1071** towards the second conductive spacer **1072** is smaller than that of an end of the second conductive spacer **1072** towards the first conductive spacer **1071**. At this time, compared to the integrated conductive spacer **107**, the height of the first conductive spacer **1071** or the second conductive spacer **1072** is relatively small, therefore, the first conductive spacer **1071** and the second conductive spacer **1072** are easily manufactured, and since the surface area of an end of the first conductive spacer **1071** towards the second conductive spacer **1072** is smaller than that of an end of the second conductive spacer **1072** towards the first conductive spacer **1071**, the first substrate **101** and the second substrate **102** are assembled more stably. It should be noted that, it is possible to make the surface area of an end of the first conductive spacer **1071** towards the second conductive spacer **1072** be larger than that of an end of the second conductive spacer **1072** towards the first conductive spacer **1071**, and it can be easily conceived that the stability of the assemblage of the first substrate **101** and the second substrate **102** with the support of the first conductive spacer **1071** and the second conductive spacer **1072** can be ensured, so long as one of surface areas of contacting surfaces of the first conductive spacer **1071** and the second conductive spacer **1072** is made be larger than the other one.

[0040] The auxiliary electrode **111** is preferably a plate-shaped auxiliary electrode **111** which is transparent and conductive. The plate-shaped auxiliary electrode **111** is made of any one of indium tin oxide, indium gallium zinc oxide, and indium zinc oxide, and of course, other transparent materials are also possible.

[0041] As shown in FIG. 3, the auxiliary electrode **111** is preferably a grid-shaped auxiliary electrode and provided in a non-display region (that is, regions corresponding to the black matrixes **108** on the first substrate **101**), and may be preferably made of any one of Al, Mo, Cu, Ag, Cr and Au or combination thereof. Of course, any other conductive material with low resistance is possible, and the thickness of the auxiliary electrode **111** is in a range of 50-300nm. At this time, the grid-shaped auxiliary electrode **111** is preferably made of opaque conductive material, and in this case, it is possible that no black matrix **108** is provided on the first substrate **101**, and the grid-shaped auxiliary electrode **111** acts as the black matrix **108**, the resistance of the material of the grid-shaped auxiliary electrode **111** is lower than that of the cathode, which may improve the conductivity of the cathode layer **106**. Of course, bar-shaped auxiliary electrodes **111** are also possible and provided in the non-display region, and all of the bar-shaped auxiliary electrodes may be electrically connected to each other through at least one connection stripe.

[0042] Preferably, a reflective layer is provided below the anode layer **104** of the organic electroluminescent device, and the reflective layer is used to reflect light emitted from the organic electroluminescent device to the cathode layer **106** of the organic electroluminescent device. Specifically,

the reflective layer may be provided on the anode layer **104** of the organic electroluminescent device at a side far away from the first substrate **101**, but position of the reflective layer is not limited thereto. The reflective layer may be made of a reflective material, such as Ag and Al. Since light frequently transmits the anode layer **104**, by adding the reflective layer, light incident onto the anode layer **104** may be reflected to the cathode layer side, and outgoes from the cathode layer **106** of the organic electroluminescent device, therefore, utilization of the emergent light of the organic electroluminescent device may be increased, and in a case of other conditions being the same, power consumption of the organic electroluminescent device may be reduced.

[0043] Preferably, the organic electroluminescent device is an organic electroluminescent device emitting white light. As to the white light-emitting organic electroluminescent device, patterns **109** of red filter, green filter and blue filter are provided on the first substrate **101** at a side close to the second substrate **102**, and of course, the organic electroluminescent device may preferably be an organic electroluminescent device emitting red light, green light or blue light.

[0044] It should be noted that, in the above description of the present embodiment, in order to better understand the disclosure, description is made by taking the first substrate **101** being a color filter substrate and the second substrate **102** being an array substrate as an example. However, the disclosure is not limited thereto, for example, the organic electroluminescent device may be a colorized organic electroluminescent device, which can emit red light, green light or blue light, at this time, it is unnecessary to manufacture the color filter patterns **109**, and the first substrate **101** may be a transparent substrate and assembled with the second substrate **102** to form a display panel.

#### Embodiment 2

[0045] The present embodiment provides a manufacturing method of a display panel, which comprises following steps:

[0046] Step 1, forming a pattern including an auxiliary electrode **111** on a light entering surface of a first substrate **101** by a patterning process.

[0047] Step 2, forming a pattern including conductive spacers **107** on the auxiliary electrode **111** by a patterning process; and

[0048] Step 3, assembling the first substrate **101** and a second substrate **102**, so that the auxiliary electrode **111** is electrically connected to cathode layers **106** of organic electroluminescent devices through the conductive spacers **107**, wherein the cathode layer **106** is a transparent electrode layer.

[0049] Specifically, first, black matrixes (BM) are formed on a first base by coating, exposure, development and baking processes and the like, red (R), green (G) and blue (B) color filter patterns **109** are formed above the black matrixes **108** respectively by coating, exposure, development and baking processes and the like, then a planarization layer **110** is coated, and a layer of metal or metal oxide is deposited on the planarization layer **110** by sputtering. Plasma Enhanced Chemical Vapor Deposition (PECVD) method, evaporation or the like and then a patterning process is performed thereon to form a pattern including the auxiliary electrode **111**, and conductive spacers **107** are formed above the auxiliary electrode **111** by a patterning process. In a case of the auxiliary electrode **111** being made of a transparent material, it may be plate-shaped or of other shape. In a case

of the auxiliary electrode **111** being made of an opaque material, in order to enable light to transmit, the auxiliary electrode **111** is preferably grid-shaped and provided in a non-display region so as to ensure light emitted from the organic electroluminescent devices may transmit the first substrate **101**, at this time, it is possible that no black matrix **108** is provided on the first substrate **101**. Of course, it is also possible that the auxiliary electrode **111** may be formed as bar-shaped auxiliary electrodes, and all of the bar-shaped auxiliary electrodes are electrically connected together through at least one connection stripe.

**[0050]** The plate-shaped auxiliary electrode **111** is made of any one of indium tin oxide, indium gallium zinc oxide, and indium zinc oxide, or may be made of other transparent conductive material. The grid-shaped auxiliary electrode **111** may be made of any one of aluminium (Al), molybdenum (Mo), copper (Cu), silver (Ag), chrome (Cr) and gold (Au) or combination thereof, of course, material of the plate-shaped auxiliary electrode is not limited thereto, other opaque conductive materials are possible, and the plate-shaped auxiliary electrode may have a thickness of **50-300nm**.

**[0051]** The conductive spacer **107** may be made of a conductive organic material, such as polyacetylene, PPV (Poly-(P-phenylenevinyle)), PTH (polythiophenes), PPP (poly p-phenylene), PPy (polypyrroles), PANI (polyaniline), PEDOT (poly(3,4-ethylenedioxythiophene)) or combination thereof.

**[0052]** Next, a gate is formed on a second base by sputtering, exposure, development, etching, peeling off processes and the like, a gate insulation layer is formed above the gate by a plasma enhanced chemical vapor deposition method and the like, an active layer of oxide semiconductor is formed above the gate insulation layer by sputtering, exposure, development, etching, peeling off processes and the like, an etch stopper layer (ESL) is formed above the active layer by sputtering, exposure, development, etching, peeling off processes and the like, a drain and a source are formed above the etch stopper layer by sputtering, exposure, development, etching, peeling off processes and the like so that the drain and the source are connected to the active layer of oxide semiconductor through contact vias passing through the etch stopper layer, a passivation protection layer is formed above the drain and the source, a pixel electrode layer **104** is formed above the passivation protection layer so that the pixel electrode layer **104** is connected to the drain through a via passing through the passivation protection layer, a pixel defining layer (PDL) is formed above the pixel electrode layer **104** which is the anode layer **104** of the organic electroluminescent device, and a light emitting layer **105** and a cathode layer **106** required for the light emitting layer **105** are evaporated on the pixel electrode layer **104**.

**[0053]** The gate may be of a single-layered structure or a multilayered composite laminated structure made of one or more of molybdenum (Mo), alloy of molybdenum and niobium (MoNb), aluminum (Al), alloy of aluminum and neodymium (AlNd), titanium (Ti) and copper (Cu), and preferably is of a single-layered structure or a multilayered composite laminated structure made of Mo, Al or alloy containing Mo and Al. Thickness of the gate is 100 nm~500 nm.

**[0054]** In the present embodiment, the gate insulation layer may be a multilayered composite film made of one or two of silicon oxide (SiOx), silicon nitride (SiNx), hafnium

oxide (HfOx), silicon nitrogen oxide (SiON) and aluminum oxide (AlOx), and, and thickness thereof is controlled to be about 100~600 nm and adjustable as desired.

**[0055]** The active layer of oxide semiconductor may be a thin film made of elements including Indium (In), gallium (Ga), zinc (Zn), oxygen (O), stannum (Sn) etc. and is formed by sputtering, wherein the thin film must be made of oxygen element and two or more of the above elements, such as indium gallium zinc oxide (IGZO), indium zinc oxide (IZO), indium tin oxide (InSnO), indium gallium stannum oxide (InGaSnO) and the like. The active layer of oxide semiconductor is preferably made of IGZO and IZO, and thickness thereof is preferably 10~100 nm.

**[0056]** The etch stopper layer may be made of a material, such as SiOx, SiNx, HfOx, SiON, AlOx etc. and may be a multilayered film made of two or three of the above materials.

**[0057]** The source and the drain may be a single-layered structure or a multilayered composite laminated structure made of one or more of Mo, MoNb, Al, AlNd, Ti and Cu, and preferably is of a single-layered film or a multilayered composite film made of Mo, Al or alloy containing Mo and Al.

**[0058]** The passivation protection layer may be made of one of SiOx, SiNx, HfOx, SiON, AlOx and organ materials or combination thereof.

**[0059]** The pixel electrode layer **104**, i.e., the anode layer **104** of the organic electroluminescent device, may be made of ITO (indium tin oxide), of course it also may be made of other transparent conductive material. Since the pixel electrode layer **104** is transparent, it is necessary to provide a reflective layer under the anode layer **104** to reflect light emitted from the organic electroluminescent device to the cathode layer **106** side, and the reflective layer may be made of a reflective metal material such as Ag.

**[0060]** The pixel defining layer may be an organic insulating layer with lower moisture and has photosensitive property similar to that of the common photoresist.

**[0061]** The light emitting layer **105** is made of an organ material, which is determined as desired.

**[0062]** The cathode layer **106** may be made of a metal material with low work function, such as Al or Ag, and is thin enough to enable light to transmit.

**[0063]** Finally, the resultant first substrate **101** and the resultant second substrate **102** are encapsulated to form a display panel.

**[0064]** It should be noted that, there is no sequencing for manufacturing the first substrate **101** and manufacturing the auxiliary electrode **111** and the conductive spacers **107** on the first substrate **101**, and manufacturing the second substrate **102** (including the thin film transistors **103** and the organic electroluminescent devices thereon), the above description is just an example, and it is also possible to first manufacture the second substrate **102**, then manufacture the first substrate **101** and manufacture the auxiliary electrode **111** and the conductive spacers **107** on the first substrate **101**.

**[0065]** In the display panel manufactured by the manufacturing method provided by the present embodiment, the cathode layer **106** thereof is connected to the auxiliary electrode **111** through the conductive spacers **107**, and the conductivity of the cathode layer **106** is improved significantly, and thus the luminance uniformity of the display panel is improved.

[0066] It should be noted that, in the present embodiment, the first substrate 101 is a color filter substrate, and the second substrate 102 is an array substrate, but the disclosure is not limited thereto. For example, when the manufactured organic electroluminescent device is a colorized organic electroluminescent device which may emit red light, green light or blue light, it is unnecessary to manufacture color filter patterns 109, and at this time, the first substrate 101 may be a transparent substrate, and a display panel may be formed by assembling the first substrate 101 and the second substrate 102. The above structures may be set as desired.

#### Embodiment 3

[0067] The present embodiment provides a manufacturing method of a display panel, which comprises following steps:

[0068] Step 1, forming a pattern including an auxiliary electrode on a light entering surface of a first substrate 101 by a patterning process.

[0069] Step 2, forming a pattern including conductive spacers 107 on a cathode layer 106 of a second substrate 102 at positions corresponding to the auxiliary electrode 111 by a patterning process.

[0070] Step 3, assembling the first substrate 101 and a second substrate 102, so that the auxiliary electrode 111 is electrically connected to the cathode layer 106 of the organic electroluminescent device through the conductive spacers 107, wherein the cathode layer 106 is a transparent electrode layer.

[0071] It should be noted that, the sequence of the step 1 and the step 2 may be reversed, that is to say, it is also possible to form the conductive spacers 107 on the cathode layer 106 of the second substrate 102 first, then form the auxiliary electrode 111 on a light entering surface of a first substrate 101 at positions corresponding to the conductive spacers 107.

[0072] In the manufacturing method of a display panel provide by the present embodiment, the conductive spacers 107 are provided on the second substrate 102, other procedures are the same as those in the manufacturing method of a display panel provide by the embodiment 1, and will not be repeatedly described herein.

[0073] In the display panel manufactured by the manufacturing method provided by the present embodiment, the cathode layer thereof is connected to the auxiliary electrode 111 through the conductive spacers 107, the conductivity of the cathode layer 106 is improved remarkably, and thus the luminance uniformity of the display panel is improved.

#### Embodiment 4

[0074] As shown in FIG. 5, the present embodiment provides a manufacturing method of a display panel, which comprises following steps.

[0075] Step 1, forming a pattern including an auxiliary electrode on a light entering surface of a first substrate 101 by a patterning process, and forming a pattern including first conductive spacers 1071 on the auxiliary electrode 111 by a patterning process.

[0076] Step 2, forming a pattern including second conductive spacers 1072 on a cathode layer 106 of a second substrate 102 at positions corresponding to the first conductive spacers 1071 by a patterning process.

[0077] Step 3, assembling the first substrate 101 and a second substrate 102, so that the auxiliary electrode 111 is

electrically connected to the cathode layers 106 of the organic electroluminescent device through the first conductive spacers 1071 and the second conductive spacers 1072, wherein the cathode layer 106 is a transparent electrode layer. A display panel as shown in FIG. 5 is obtained.

[0078] It should be noted that, the sequence of the step 1 and the step 2 may be reversed, that is to say, it is also possible to form the second conductive spacers 1072 on the second substrate 102 first, and then form the first conductive spacers 1071 above the auxiliary electrode 111 on the light entering surface of the first substrate 101 at positions corresponding to the second conductive spacers 1072.

[0079] In the manufacturing method of a display panel provide by the present embodiment, the conductive spacer 107 is divided into a first conductive spacer 1071 and a second conductive spacer 1072, which are manufactured on the first substrate 101 and the second substrate 102 respectively, at this time, compared to the height of the conductive spacer 107 in the embodiment 1 or 2, the height of the first conductive spacer 1071 or the second conductive spacer 1072 in the present embodiment is lower, thus the first conductive spacer 1071 and the second conductive spacer 1072 are easy to be manufactured. One of the first conductive spacer 1071 and the second conductive spacer 1072 is wider than the other one, that is, the surface area of an end of one of the first conductive spacer 1071 and the second conductive spacer 1072 towards the other one of the first conductive spacer 1071 and the second conductive spacer 1072 is larger than that of an end of the other one towards the one, so that the first substrate 101 and the second substrate 102 are assembled more stably. Other manufacturing procedures of the manufacturing method of the present embodiment are the same as those in the embodiment 1, and will not be repeatedly described herein. Of course, in the present embodiment, the first conductive spacer 1071 and the second conductive spacer 1072 may also be manufactured on the first substrate 101 and the second substrate 102 respectively, and manufacturing procedures thereof are the same as the above case in the present embodiment, and will not be repeatedly described herein.

[0080] In the display panel manufactured by the manufacturing method provided by the present embodiment, the cathode layer 106 thereof is connected to the auxiliary electrode 111 through the first conductive spacers 1071 and the second conductive spacers 1072, the conductivity of the cathode layer 106 is improved significantly, and thus the luminance uniformity of the display panel is improved.

#### Embodiment 5

[0081] The present embodiment provides a display device comprising the display panel of the embodiment 1. The display device may be any product or component with display function, such as a mobile phone, a tablet computer, a TV, a display, a notebook computer, a digital image frame, a navigator.

[0082] In the display device comprising the display panel of the embodiment 1, the cathode layer thereof is connected to the auxiliary electrode 111 through the conductive spacers 107, the conductivity of the cathode layer 106 is improved significantly, the luminance uniformity of the display panel is improved, and thus the display effect of the display device is excellent.

[0083] Of course, the display device of the present embodiment may further comprise other conventional structures, such as a power supply unit, a display driving unit and the like.

[0084] It should be understood that, the above embodiments are only exemplary embodiments employed to illustrate the principle of the disclosure, and the disclosure is not limited thereto. Persons skilled in the art can make various modifications and improvements without departing from the principle and substance of the disclosure, and these modifications and improvements should be considered to be within the protection scope of the disclosure.

1. A manufacturing method of a display panel, comprising steps of:

forming a pattern including an auxiliary electrode on a light entering surface of a first substrate by a patterning process;

forming a pattern including conductive spacers on at least one of the auxiliary electrode and a cathode layer of a second substrate by a patterning process; and

assembling the first substrate and a second substrate, so that the auxiliary electrode is electrically connected to a cathode layer of an organic electroluminescent device through the conductive spacers, wherein the cathode layer is a transparent electrode layer.

2. The manufacturing method of claim 1, wherein forming a pattern including conductive spacers on at least one of the auxiliary electrode and a cathode layer of a second substrate by a patterning process comprises:

forming a pattern including conductive spacers on the auxiliary electrode by a patterning process.

3. The manufacturing method of claim 1, wherein forming a pattern including conductive spacers on at least one of the auxiliary electrode and a cathode layer of a second substrate by a patterning process comprises:

forming a pattern including conductive spacers on the cathode layer of the second substrate at positions corresponding to the auxiliary electrode by a patterning process.

4. The manufacturing method of claim 1, wherein forming a pattern including conductive spacers on at least one of the auxiliary electrode and a cathode layer of a second substrate by a patterning process comprises:

forming a pattern including first conductive spacers on the auxiliary electrode by a patterning process, and forming a pattern including second conductive spacers on the cathode layer of the second substrate at positions corresponding to the first conductive spacers by a patterning process.

5. The manufacturing method of claim 4, wherein assembling the first substrate and a second substrate, so that the auxiliary electrode is electrically connected to a cathode layer of an organic electroluminescent device through the conductive spacers comprises:

assembling the first substrate and the second substrate, so that the auxiliary electrode is electrically connected to the cathode layer of the organic electroluminescent device through the first conductive spacers and the second conductive spacers.

6. The manufacturing method of claim 4, wherein the auxiliary electrode has a resistance smaller than that of the cathode layer of the organic electroluminescent device.

7. The manufacturing method of claim 1, wherein the conductive spacers are made of any one of polyacetylene,

PPV, polythiophene, poly p-phenylene, polypyrrole, polyaniline, poly(3,4-ethylenedioxythiophene) or combination thereof.

8. The manufacturing method of claim 4, wherein a surface area of an end of the first conductive spacer facing the second conductive spacer is smaller than that of an end of the second conductive spacer facing the first conductive spacer.

9. The manufacturing method of claim 1, wherein the auxiliary electrode is formed as a plate-shaped auxiliary electrode which is transparent and conductive.

10. The manufacturing method of claim 9, wherein the plate-shaped auxiliary electrode is made of any one of indium tin oxide, indium gallium zinc oxide, and indium zinc oxide.

11. The manufacturing method of claim 1, wherein the auxiliary electrode is formed as a grid-shaped auxiliary electrode and provided in a non-display region.

12. The manufacturing method of claim 11, wherein the grid-shaped auxiliary electrode is made of any one of Al, Mo, Cu, Ag, Cr and Au or a combination thereof.

13. The manufacturing method of claim 1, further comprising:

forming a reflective layer below an anode layer of the organic electroluminescent device, and the reflective layer is configured to reflect light emitted from the organic electroluminescent device to the cathode layer of the organic electroluminescent device.

14. A display panel comprising a first substrate and a second substrate which are assembled, wherein

the second substrate is provided with an organic electroluminescent device thereon, an anode layer of the organic electroluminescent device is away from the first substrate and a cathode layer thereof is closer to the first substrate than the anode layer;

the cathode layer of the organic electroluminescent device is electrically connected to an auxiliary electrode on a light entering surface of the first substrate through a plurality of conductive spacers spaced, and the cathode layer is a transparent electrode layer; and

the auxiliary electrode has a resistance smaller than that of the cathode layer of the organic electroluminescent device;

wherein the auxiliary electrode is a grid-shaped auxiliary electrode and is provided in a non-display region, and the auxiliary electrode is opaque and acts as a black matrix.

15. The display panel of claim 14, wherein the grid-shaped auxiliary electrode is made of any one of Al, Mo, Cu, Ag, Cr and Au or a combination thereof.

16. A display panel comprising a first substrate and a second substrate which are assembled, wherein

the second substrate is provided with an organic electroluminescent device thereon, an anode layer of the organic electroluminescent device is away from the first substrate and a cathode layer thereof is closer to the first substrate than the anode layer;

the cathode layer of the organic electroluminescent device is electrically connected to an auxiliary electrode on a light entering surface of the first substrate through a plurality of conductive spacers spaced, and the cathode layer is a transparent electrode layer; and

the auxiliary electrode has a resistance smaller than that of the cathode layer of the organic electroluminescent device;

wherein the auxiliary electrode comprises a plurality of bar-shaped auxiliary electrodes connected to each other through at least one connection stripe.

**17.** The display panel of claim **16**, wherein the bar-shaped auxiliary electrode is made of any one of Al, Mo, Cu, Ag, Cr and Au or a combination thereof.

**18.** A display device comprising the display panel of claim **14**.

**19.** A display device comprising the display panel of claim **16**.

\* \* \* \* \*

专利名称(译)	显示面板及其制造方法和显示装置		
公开(公告)号	<a href="#">US20190252616A1</a>	公开(公告)日	2019-08-15
申请号	US16/393153	申请日	2014-07-15
[标]申请(专利权)人(译)	京东方科技集团股份有限公司		
申请(专利权)人(译)	京东方科技集团股份有限公司.		
当前申请(专利权)人(译)	京东方科技集团股份有限公司.		
[标]发明人	KONG XIANGYONG WANG DONGFANG		
发明人	KONG, XIANGYONG WANG, DONGFANG		
IPC分类号	H01L51/00 H01L51/52 H01L51/56 H01L51/50		
CPC分类号	H01L51/0024 H01L51/5228 H01L51/0023 H01L51/525 H01L51/5234 H01L51/5218 H01L51/56 H01L51/5271 H01L51/5036 H01L27/322 H01L2251/5315		
优先权	201310557149.5 2013-11-11 CN 14/422271 2015-02-18 US		
外部链接	<a href="#">Espacenet</a> <a href="#">USPTO</a>		

摘要(译)

本发明提供一种显示面板及其制造方法。显示面板显示面板包括组装的第一基板和第二基板，第二基板上设置有有机电致发光器件，有机电致发光器件的阳极层远离第一基板，阴极层较近到阳极层的第一基板；有机电致发光器件的阴极层通过多个导电垫片电连接到第一基板的光进入表面上的辅助电极，阴极层是透明电极层；辅助电极的电阻小于有机电致发光器件的阴极层的电阻；辅助电极是栅格状的辅助电极，设置在非显示区域，辅助电极是不透明的，起黑色矩阵的作用。

